

Veljan 3 - ports pressure compensator Valve Series VR5P are designed for improved operation safety and reduced mounting cost. These valves are used to maintain a constant pressure drop across a metering orifice (flow control valve or throttle valve) irrespective of actuator load variation in a hydraulic system and thus maintain a constant and stable flow to the actuator.

The pilot stage of VR5P valves are designed to reduce pressure overshoot and minimise cracking flow, thus reducing power and speed reduction loss during high pressure operation. When fitted across a metering orifice with its pilot taken from outlet of a metering orifice, VR5P acts as a load sensor and relieves metering orifice inlet at load created pressure which is lower than the system setting pressure at VR5P. This enables the system to consume less power and be more efficient.

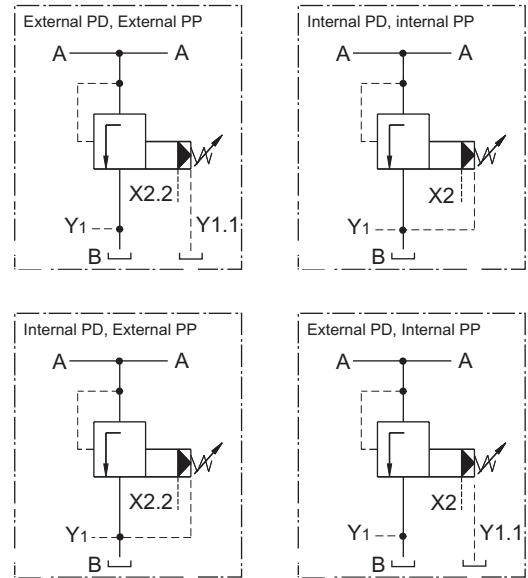

Typical application
VR5P with flow control valve

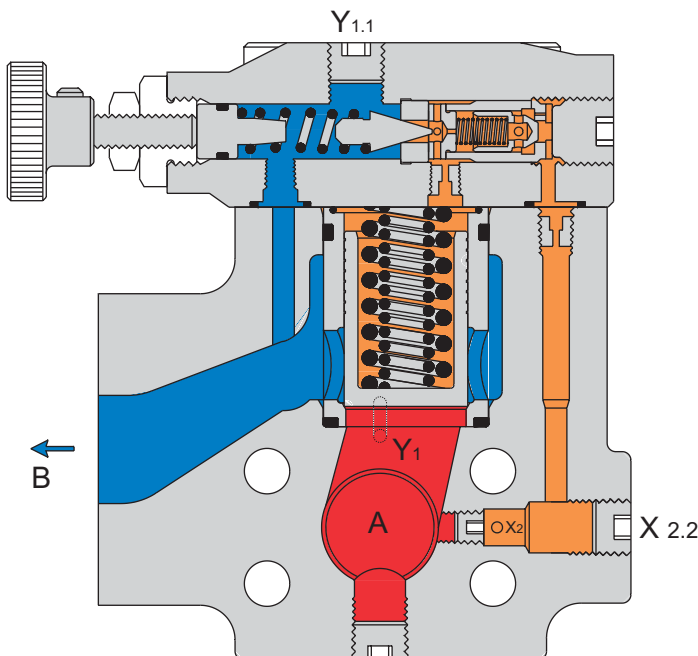
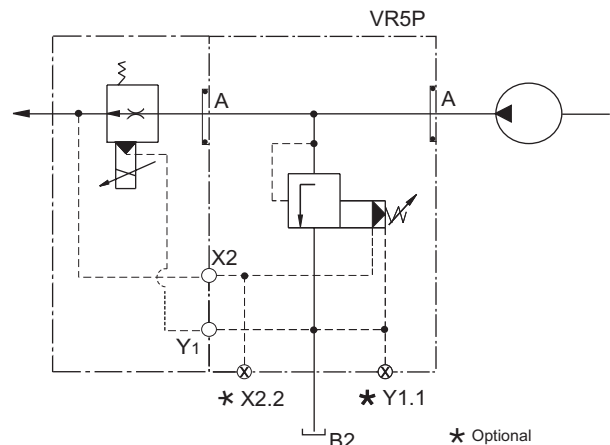

VR5P valves can be used as flanged body type units as well as for direct mounting on SAE pumps, motors or manifolds. These are also available as cartridge type for individual manifolds mounting.

VR5P valves consist of a high flow poppet type seat valve section controlled by the low flow, adjustable pilot section mounted on top. Pressure setting is achieved by means of a knurled knob. For tamper proof setting, an acorn nut with lead seal is available as an option. Optional vent valve VV01 sandwiched between pilot section and main body can be used for venting the VR5 valves.

SPECIFICATIONS

PC

General

Type	:	Pilot operated Pressure Compensator Valve
Design	:	Poppet type
Mounting	:	Flanged According to SAE - 3000 psi (210 bar) e.g. Directly on a pump
Mounting position	:	Optional
Port sizes (nominal)	:	3/4", 1", 1 1/4"
Direction of flow	:	A→B
Ambient temperature	:	-20°C...+60°C (-4°F...+140°F)
Special working conditions	:	Consult VELJAN

Hydraulics

Pressure control range	:	Minimum - depends on flow Maximum - 5000 psi (350 bar) for VR5P06/ VR5P08 4050 psi (280 bar) for VR5P10
Maximum operating pressure	:	
Port A (inlet)	:	5000 psi (350 bar) for VR5P06/ VR5P08 4050 psi (280 bar) for VR5P10
Port B (outlet)	:	Open to tank
Port X (pilot)	:	120 psi (8.4 bar) less than inlet (port A) pressure
Port Y, Y ₁ (Pilot drain)	:	Open to tank
	:	
Maximum flow gpm (lpm)	:	VR5P 06 (3/4") 24 (90) VR5P 08 (1") 80 (300) VR5P10 (1 1/4") 160 (600)
Nominal flow gpm (lpm)	:	depends on pump delivery
Fluid	:	Mineral oil as per DIN 51524/25 or other fluids on request
Fluid Temperature Range	:	-18°C...+80°C (0°F...c+176°F)
Viscosity Range	:	10 to 650 cSt (60 to 3900 SSU)
Optimum operating viscosity	:	30 cSt (180 SSU)
Seal compatibility	:	Code 1 (Buna N) or Code 5 (Viton) (contact Veljan with specific oil details)
Cleanliness recommended	:	Better than NAS 1638 Class 8 or ISO 17/14

Adjustment

Manual	:	Handwheel
Rotation	:	3.75 rev.
Operating torque	:	0.72 Nm
Electricals (Vent Valve VVV01)	:	Solenoid
Nominal voltage	:	Refer to Ordering Code
Permissible voltage fluctuation	:	+5%...-10%
Max. coil temperature	:	+155° C (311°F)
Type of current	:	Alternating Current (AC)/Direct Current (DC)
Input power	:	31 W
Holding	:	78 VA
Inrush	:	264 VA
Relative operating period	:	100%
Type of protection	:	I P 65

ORDERING CODE

VR5P 06 - 5 1 5 - 1 2 - 09 - W07 - A 1 ***

Series

VR5P = 3 Port Compensator

Size

- 06 - 3/4"
- 08 - 1"
- 10 - 1 1/4"

Max. Pressure of Valve Body

- 0 - for Cartridge only
- 4 - 4000psi (280 bar) - SAE 61 flange (VR5P 10)
- 5 - 5000psi (350 bar) - SAE 61 flange (VR5P 06/08)

Body

- 0 - Cartridge
- 1 - X2, Y1 closed
- 2 - X2, Y1 open (used only with internally drained flow control valve. Connection on flange face open to link with internal drain from flow control valve)

Pressure setting range

- 1 - 100 - 1500 psi (7 - 105 bar)
- 3 - 100 - 3000 psi (7 - 210 bar)
- 5 - 100 - 5000 psi (7 - 350 bar)

Type of Control

- 1 - Hand knob (32mm dia)
- 2 - Hand knob (50mm dia) (not for version with vent valve)
- 3 - Acorn nut with lead seal

Modification

Seal Class

- 1 - Buna N (Standard)
- 5 - Viton

Design letter

Solenoid Voltage

(Omit for non vent version)

- W01 - 115V/60 Hz AC GOR - 12V DC
- W02 - 230V/60 Hz AC GOQ - 24V DC
- W06 - 115V/50 Hz AC GOH - 48V DC
- W07 - 230V/50 Hz AC

Electrical Vent

(3way VENT VALVE VV01)

Omit for non vent version

- 09 - With manual override (Solenoid de-energized : open to tank. Solenoid energized : vent line blocked)
- 10 - Without manual override (Solenoid de-energized : open to tank. Solenoid energized : vent line blocked)
- 11 - With manual override (Solenoid de-energized : vent line blocked Solenoid energized : open to tank)
- 12 - Without manual override (Solenoid de-energized : vent line blocked Solenoid energized : open to tank)

Pilot Connection

- 2 - Internal PD - Internal PP*
- 4 - External PD - External PP
- 5 - Internal PD - External PP
- 6 - External PD - Internal PP*

* Internal pilot pressure connection on flange face to link with outlet port of flow control Valve



PERFORMANCE



P- Q Curves

Min. possible pressure setting ≥ 8.4 bar. (120 psi)
 Fluid 40 cSt at $50^{\circ}\text{C} \pm 0.5^{\circ}\text{C}$. (240 SSU at $120^{\circ}\text{F} \pm 32.9^{\circ}\text{F}$)

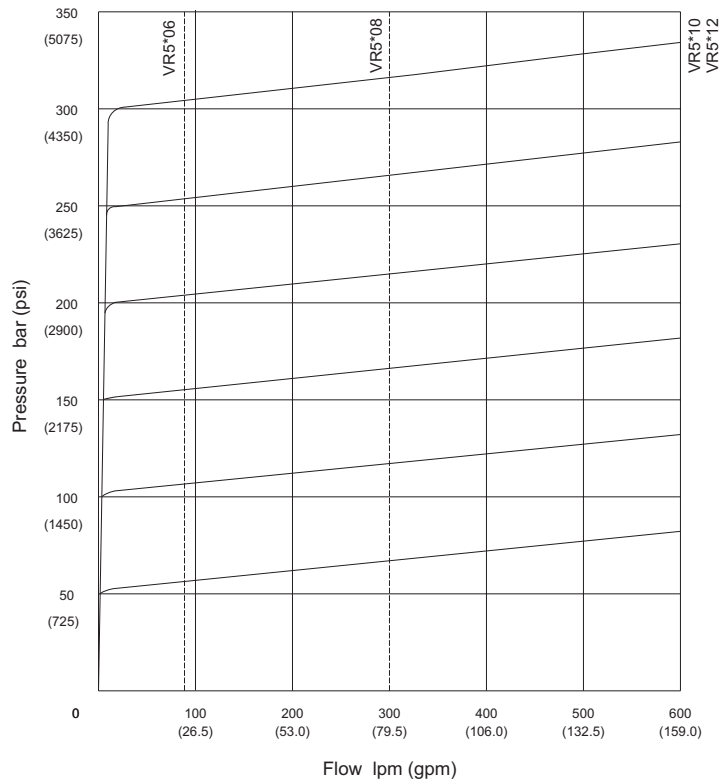

VR5P06 (3/4") - VR5P08 (1") - VR5P10 (1 1/4")

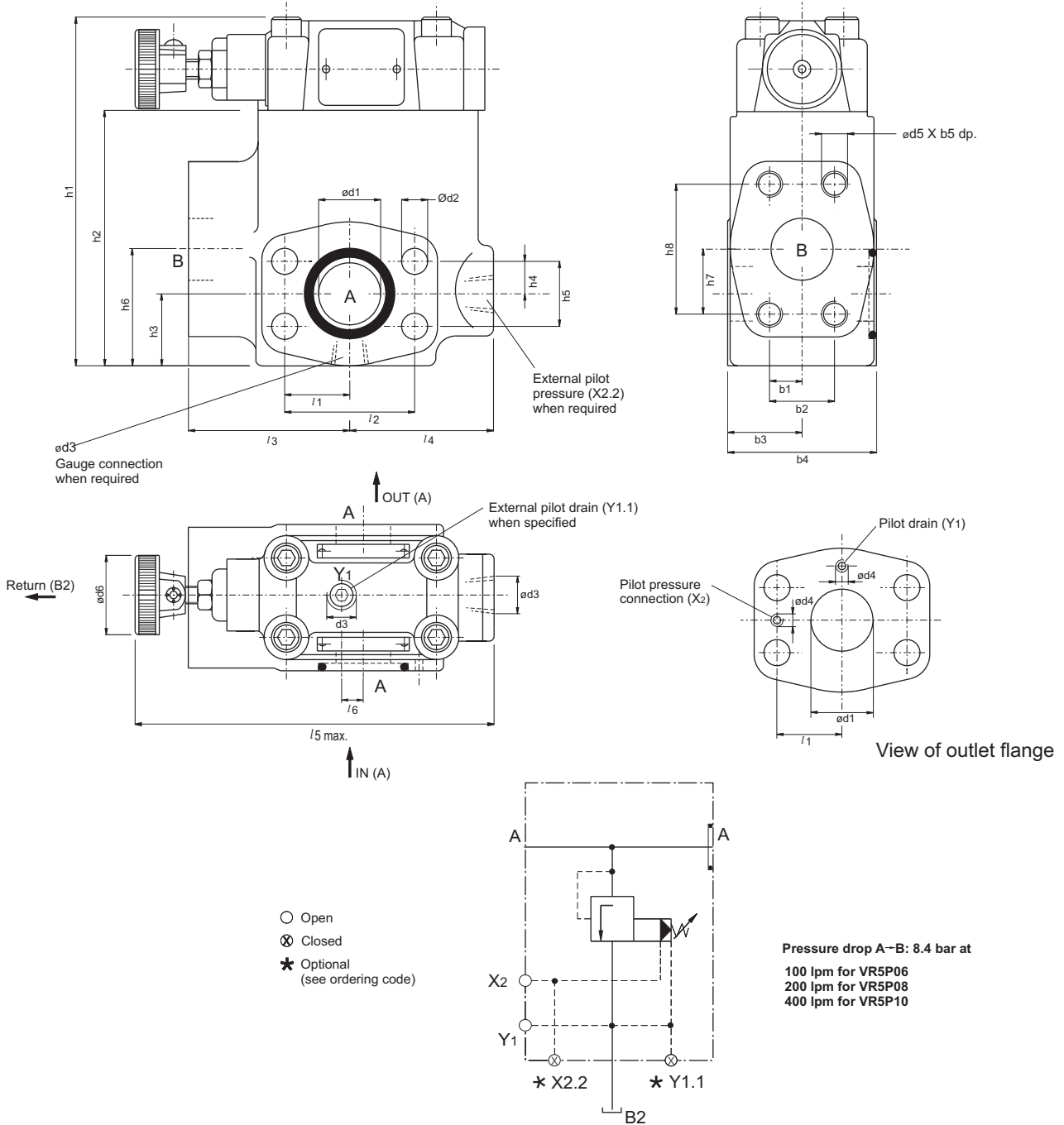

Dimensions		l1	l2	l3	l4	l5	l6	b1	b2	b3	b4	b5	h1	h2	
VR5P06 (3/4")	in	0.94	1.87	2.48	2.20	5.83	0.04	0.44	0.87	1.18	2.36	0.79	4.68	3.90	
	mm	23.80	47.60	63.00	56.00	148.00	1.00	11.10	22.20			20.00	119.00	99.10	
VR5P08 (1")	in	1.03	2.06	2.56	2.28	5.69	0.20	0.51	1.03	30.00	60.00	0.90	5.59	4.81	
	mm	26.20	52.40	65.00	58.00	144.60	5.00	13.10	26.20			23.00	142.00	122.10	
VR5P10 (1 1/4")	in	1.16	2.31	2.40	2.44	5.77	0.12	0.59	1.19	1.48	2.95	0.87	5.87	5.08	
	mm	29.40	58.70	61.00	62.00	146.60	3.00	15.10	30.20	37.50	75.00	22.00	149.00	129.10	
Dimensions		h3	h4	h5	h6	h7	h8	d1	d2	d3	d4	d5	d6	Weight	
VR5P06 (3/4")	in	1.13	0.44	0.87	1.64	0.94	1.87	0.75	0.41	10.50	1/4" NPTF	M3	3/8" UNC	1.26	8.10 lbs
	mm	28.60	11.10	22.20	41.60	23.80	47.60	19.00							3.70 kg
VR5P08 (1")	in	1.20	0.51	1.03	1.91	1.03	2.06	0.98	0.47	12.00	7/16" UNC	3/8" UNC	32.00	9.70 lbs	
	mm	30.60	13.10	26.20	48.60	26.20	52.40	25.00						4.40 kg	
VR5P10 (1 1/4")	in	1.36	0.59	1.19	2.52	1.16	2.31	1.26	0.47	12.00	7/16" UNC	3/8" UNC	32.00	11.70 lbs	
	mm	34.60	15.10	30.20	64.10	29.40	58.70	32.00						5.30 kg	

CARTRIDGES WITH PILOT VALVES VR5P08/VR5P10

Fit orifice plug
1.2 dia. Number V036-25528

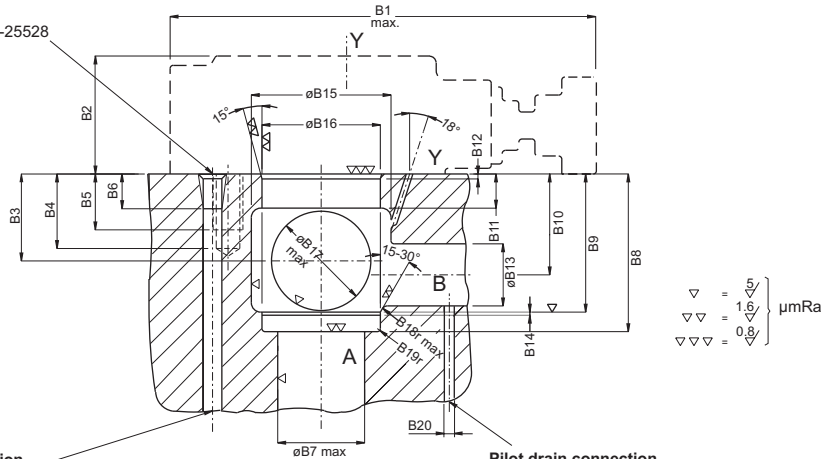

Pilot pressure connection
for VR5P connect to outlet of flow control orifice or internal pilot pressure on flange face of flow control valve

Pilot drain connection
Connect to internal pilot drain in flange face of flow control valve if internal drain is required. Connection point to outlet "B" is optional

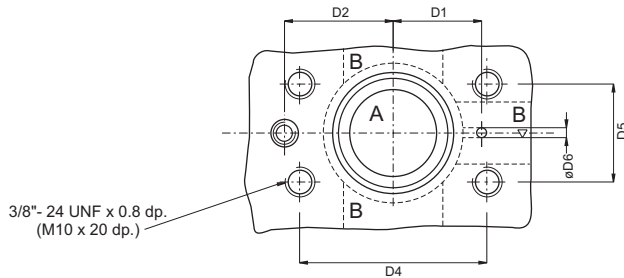

	Dimensions	
	in	mm
B1	5.55	141.0
B2	1.49	38.0
B3	1.083 ^{+0.004}	27.5 ^{+0.1}
B4	0.945	24.0
B5	0.71	18.0
B6	ø0.35	ø11.0
B7	ø1.1	ø28.0
B8	1.997 ^{+0.003}	50.73 ^{+0.07}
B9	1.75	44.5
B10	1.28	32.5
B11	0.433	11.0
B12	0.06	1.6
B13	ø0.79	Ø20.0
B14	0.04	1.0
B15	ø1.732 ^{+1.73}	ø44.0 ^{+1.0}
B16	ø1.5 ^{HB}	ø38.1 ^{HB}
B17	ø1.26	ø32.0
B18	0.08	2.0
B19	0.0157	0.4
B20	ø0.126	ø3.2

	Dimensions	
	in	mm
D1	1.122	28.5
D2	1.38 ^{+0.008}	35.0 ^{+0.2}
D3	2.37 ^{+0.008}	60.32 ^{+0.2}
D4	1.25	31.75
D5	ø0.126	ø3.2

4 Mounting screws*	
Dimensions	Order No.
3/8" - 24 UNF x 1 ^{3/4} lg.	V359 - 15220
or	or
M10 x 45mm, DIN 912 - 12.9	V700 - 71602

* Mounting screws must be ordered separately



OPTIONAL CONTROL

Type of control - Code 3
Acron nut with lead seal

Type of control - Code 2
Hand knob 50mm dia
(not for version with vent valve VVV01)

PC

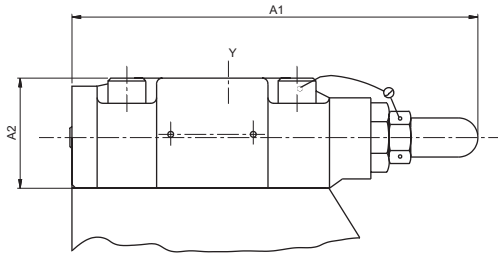

	Dimensions	
	in	mm
A1	5.51	140.0
A2	0.49	38.0

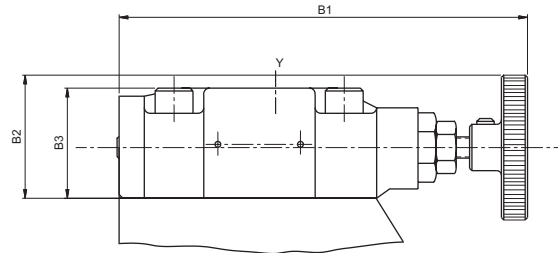

	Dimensions	
	in	mm
B1	5.55	141.0
B2	1.67	42.5
B3	1.49	38.0

Version with Vent Valve VVV01

Weight (VVV01) : 3.73 lbs (1.7 kg)

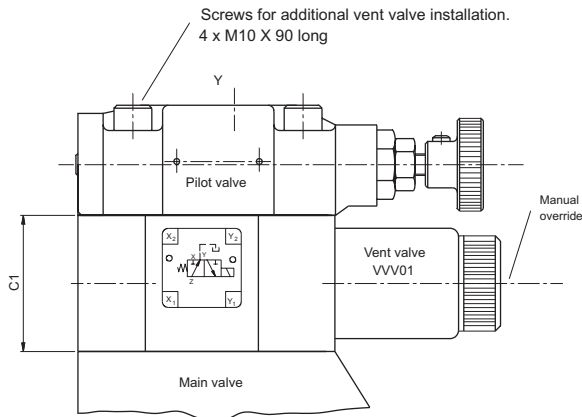

	Dimensions	
	in	mm
C1	1.85	47.0

	Dimensions	
	In	mm
D1	ø0.41	ø10.5
D2	2.03	51.8
D3	1.25	31.8
D4	0.18	4.8
D5	0.12	3.2
D6	0.81	20.6
D7	2.31	58.7
D8	2.37	60.3
D9	3.49	88.7
D10	0.51	13.0
D11	2.75	70.0

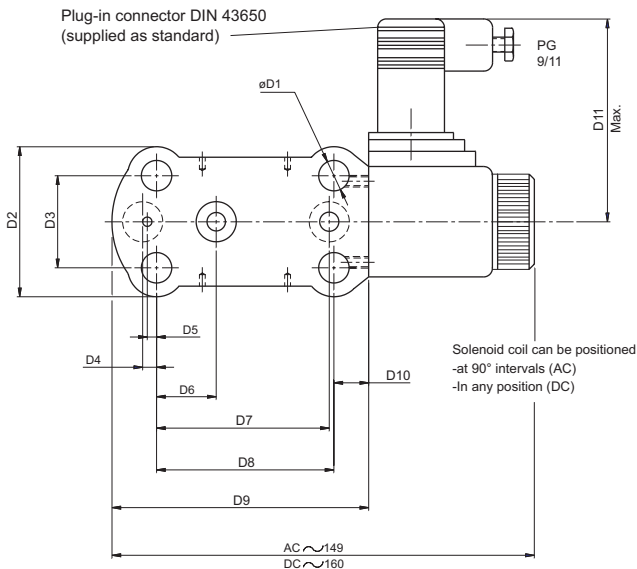

Code	Pressure Compensator Valve VR5P	
	Internal Drain	External Drain
11 or 12		
09 or 10		

SAE - Flanges with A-X connection and orifice plates

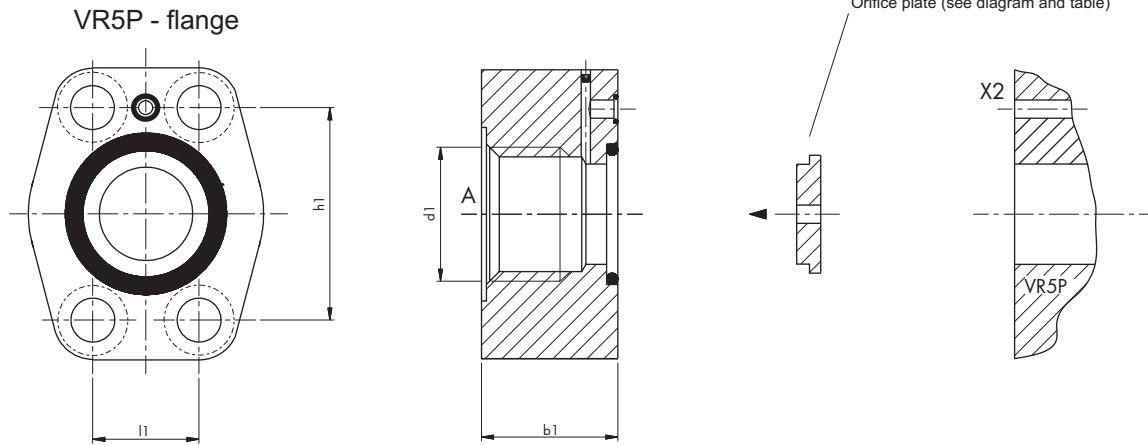

The curve below is for user to select orifice diameter (orifice plate) for desired flow. For orifice with fraction size, select the next immediate larger orifice diameter from the table.

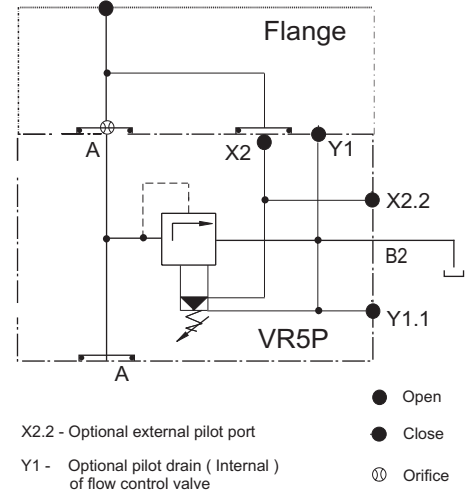
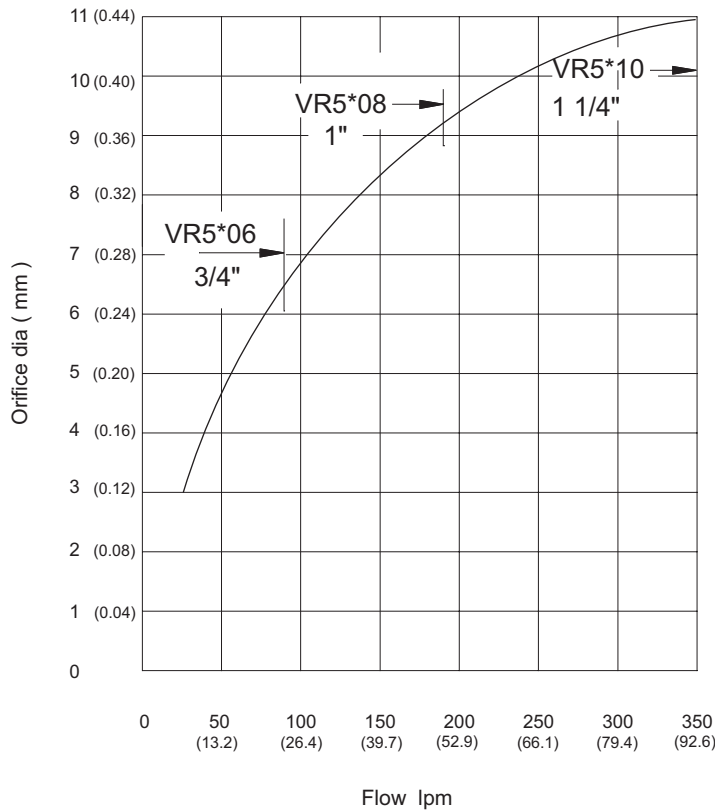

Orifice plates

Orifice dia.(mm)	Order no.		
	3/4" (VR5P06)	1" (VR5P08)	1 1/4" (VR5P10)
11.0	-	-	V036 - 84982
10.0	-	V036 - 84990	V036 - 84981
9.0	-	V036 - 84989	V036 - 84980
8.0	V036 - 84996	V036 - 84988	V036 - 84979
7.0	V036 - 84995	V036 - 84987	V036 - 84978
6.0	V036 - 84994	V036 - 84986	V036 - 84977
5.0	V036 - 84993	V036 - 84985	V036 - 84976
4.0	V036 - 84992	V036 - 84984	V036 - 84975
3.0	V036 - 84991	V036 - 84983	V036 - 84974

Flanges

for	Size d1	Order no.	b1	L1	h1
VR5P06	3/4" B.S.P.P.	VS16 - 39922 - 0	34.0	22.2	47.6
VR5P08	1" B.S.P.P.	VS16 - 39923 - 0	34.0	26.2	52.4
VR5P10	1 1/4" B.S.P.P.	VS16 - 39924 - 0	39.0	30.2	58.7

SAE - Flanges

Inlet flange (only for pipe mounting)

PC

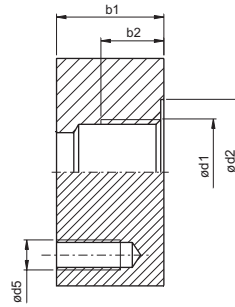
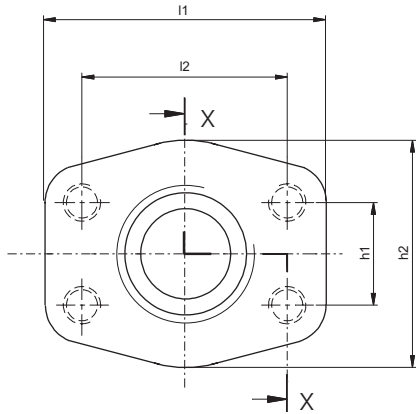

B.S.P.P. Flange

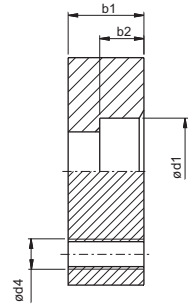

Socket weld

Outlet and tank port flange

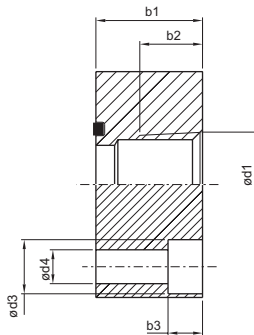
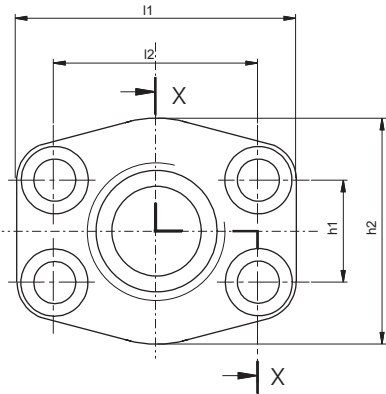

N.P.T.F. flange

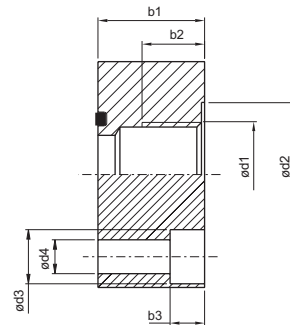

B.S.P.P. flange

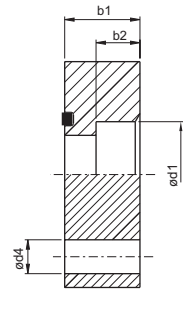

Socket weld

Port sizes d1	Inlet flange (without screws) only for pipe mounting	Outlet flange (without screws)	Tank port flange (with screws)														
	Order no.	Order no.	Order no.	l1	l2	b1	b2	b3	h1	h2	ød2	ød1	ød4	ød5			
3/4" B.S.P.P.	VS16 - 86520	VS16 - 86529	VS14 - 66933	67.0	47.6	34.0	15.9	12.0	22.0	52.0	40.0	16.5	10.5	3/8" UNC			
3/4" N.P.T.F.	-	VS16 - 86530	VS14 - 66925			19.0	12.0	-			-						
3/4" Socket weld	VS16 - 86519	VS16 - 86528	VS14 - 66941	72.0	52.4	34.0	20.0	12.0	26.2	58.0	46.0	16.5	12.5	7/16" UNC			
1" B.S.P.P.	VS16 - 86523	VS16 - 86 532	VS14 - 66934			24.0	14.0	-			-						
1" N.P.T.F.	-	VS16 - 86533	VS14 - 66926			39.0	22.0	15.0			30.2	73.0			54.0	17.5	-
1" Socket weld	VS16 - 86522	VS16 - 86531	VS14 - 66942	80.0	58.7	24.0	14.0	-	35.7	82.0	60.0	20.0	14.5	1/2" UNC			
1 1/4" B.S.P.P.	VS16 - 86526	VS16 - 86535	VS14 - 66935			39.0	24.0	15.0			30.2	73.0			54.0	17.5	-
1 1/4" N.P.T.F.	-	VS16 - 86536	VS14 - 66927			24.0	14.0	-			-	-			-	-	-
1 1/4" Socket weld	VS16 - 86525	VS16 - 86534	VS14 - 66943			39.0	24.0	15.0			35.7	82.0			60.0	20.0	14.5
1 1/2" B.S.P.P.	VS26 - 52364	VS26 - 52215	VS14 - 66936	94.0	69.8	39.0	24.0	15.0	35.7	82.0	60.0	20.0	14.5	1/2" UNC			
1 1/2" Socket weld	VS26 - 52366	VS26 - 52217	VS14 - 66944			26.0	16.0	-			-	-			-	-	-
1 1/2" B.S.P.P. ¹⁾	V464 - 01147	V464 - 01141	V464 - 01004	112.0	79.4	50.0	28.0	20.0	36.5	94.0	60.0	25.0	17.5	5/8" UNC			
1 1/2" Socket weld ¹⁾	V464 - 01149	V464 - 01143	V464 - 01146			26.0	16.0	-			-	-			-	-	-

1) SAE 62